

DTS-6(2) SERIES

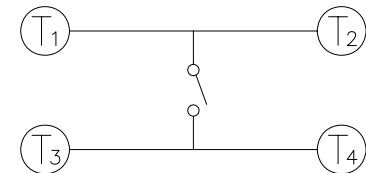

**DIMENSIONS**

DTS-61~66 □

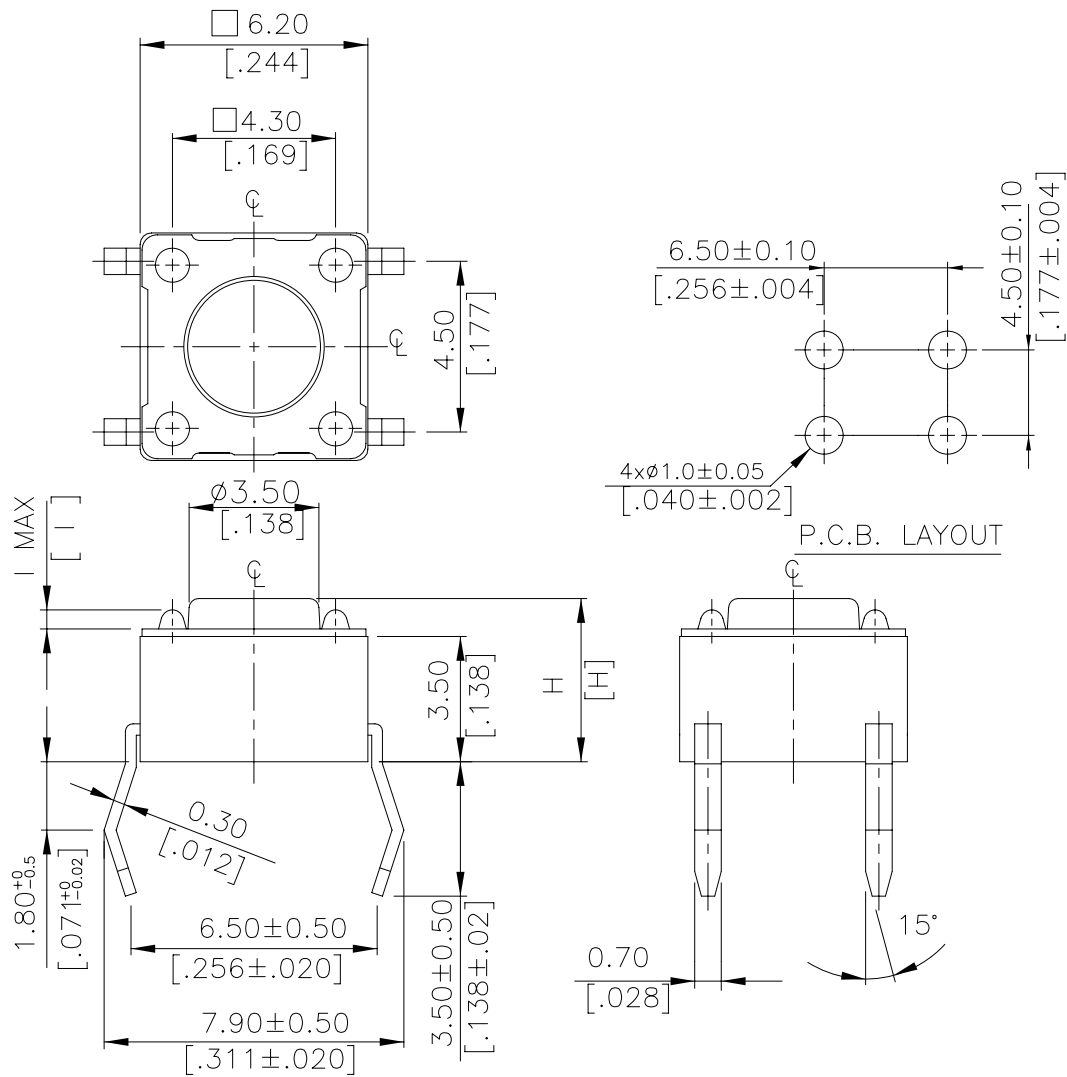

CIRCUIT DIAGRAM

DTS-62~66 □	0.6 MAX	.0236 MAX
DTS-61 □	0.5 MAX	.0197 MAX
PROD. NO.	I	INCHES.

DTS-66 □	13.0 [.512]
DTS-65 □	9.5 [.374]
DTS-63 □	7.0 [.275]
DTS-62 □	5.0 [.197]
DTS-61 □	4.3 [.169]
PROD. NO.	H

General Tolerance : ±0.2mm

DTS-644、648 □

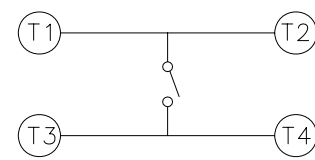
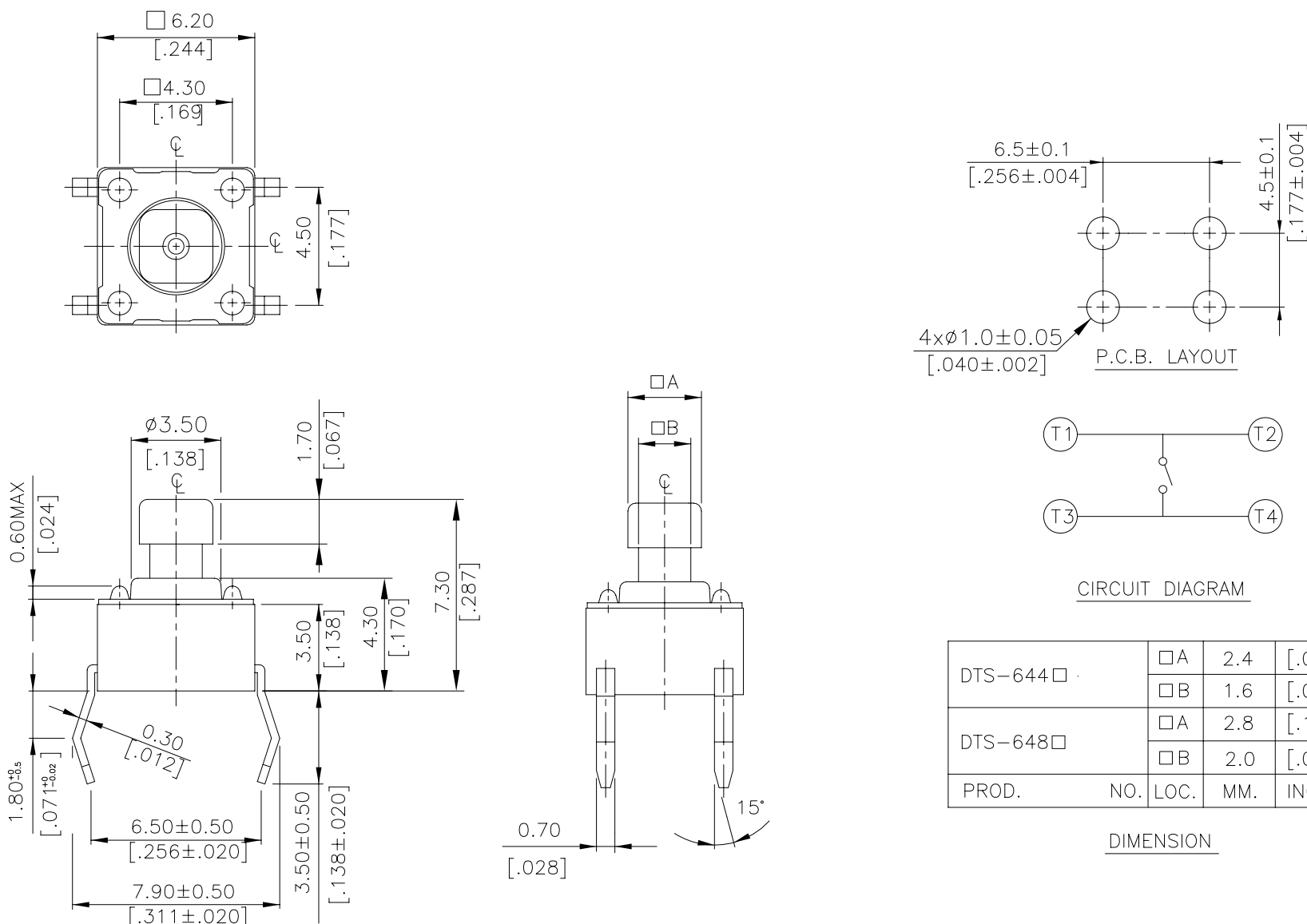

CIRCUIT DIAGRAM

DTS-644 □	□ A	2.4	[.095]
	□ B	1.6	[.063]
DTS-648 □	□ A	2.8	[.110]
	□ B	2.0	[.079]
PROD. NO.	LOC.	MM.	INCH.

DIMENSION

General Tolerance : ±0.2mm

DTS-21、25□

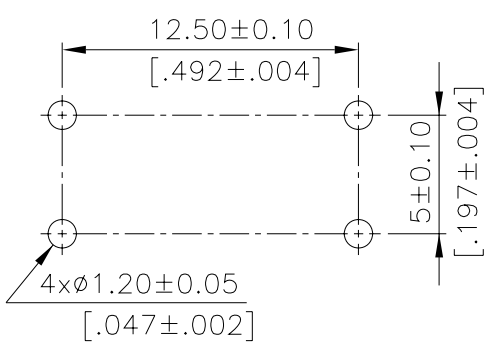
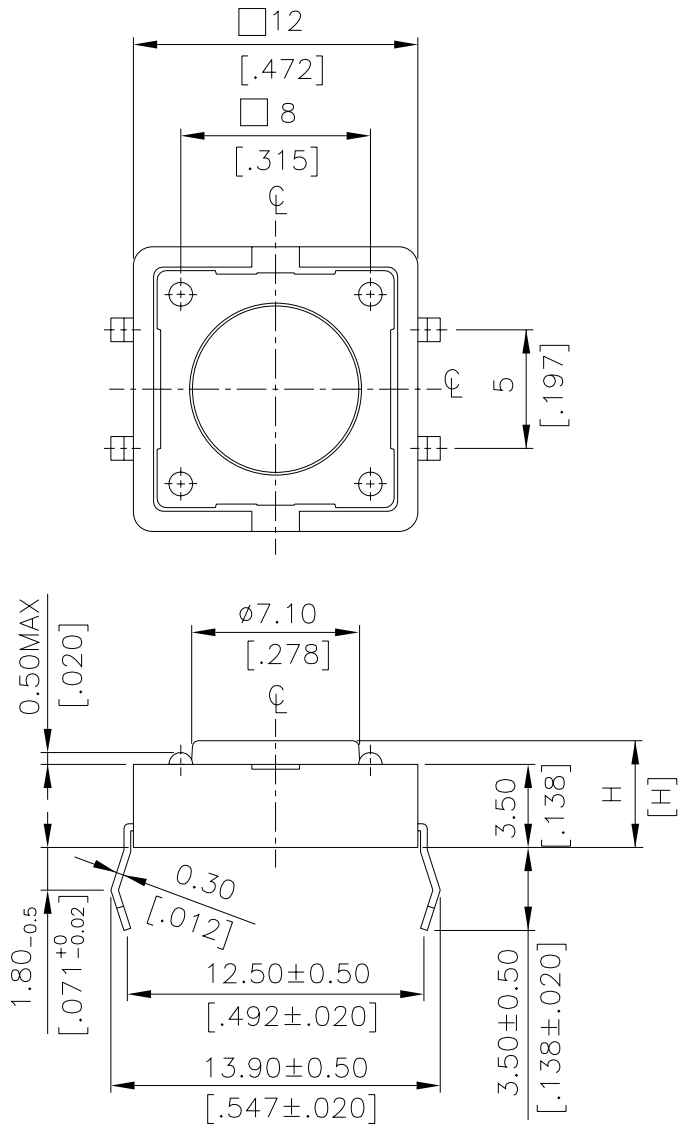

P.C.B. LAYOUT

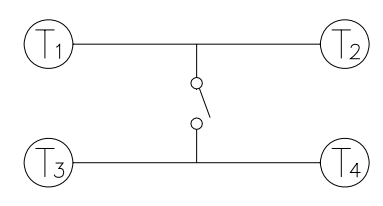

CIRCUIT DIAGRAM

DTS-25□-	8.5 [0.335]
DTS-21□-	4.3 [0.169]
PROD. NO.	H

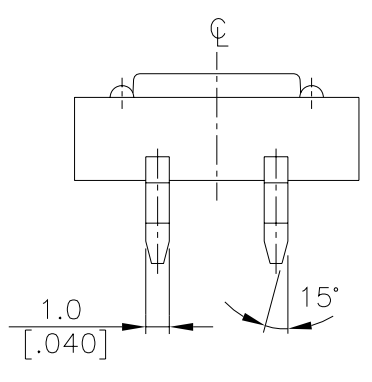

General Tolerance :  $\pm 0.2\text{mm}$

DTS-24□

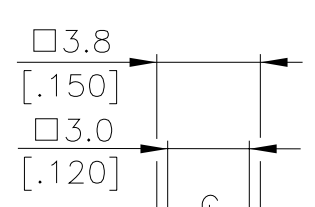
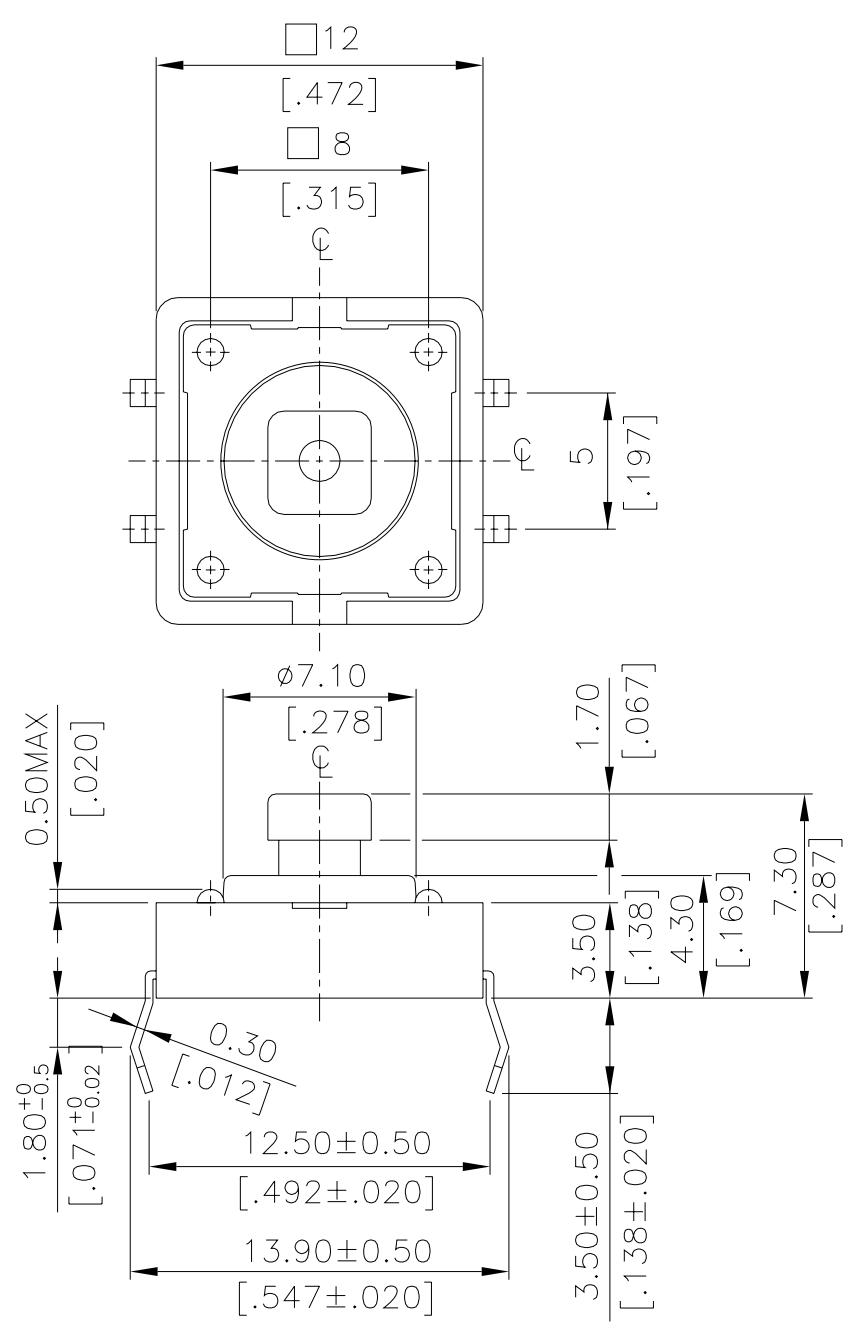

P.C.B. LAYOUT

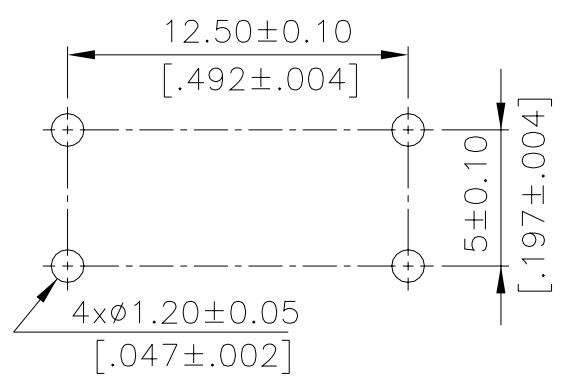

P.C.B. LAYOUT

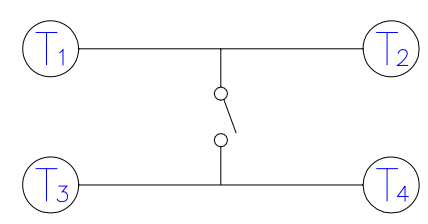

CIRCUIT DIAGRAM

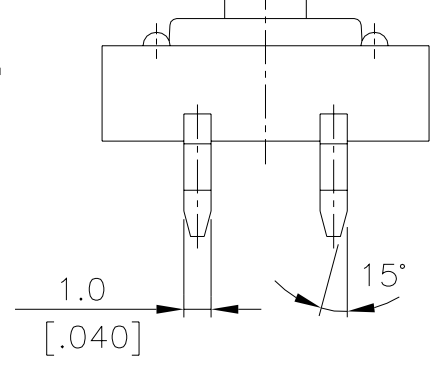

General Tolerance :  $\pm 0.2\text{mm}$

# HOW TO ORDER

D T S □ - □ □ □ - □ - □ - □

Package style:  
 □ = Bulk pack  
 ▲ B = Tube  
 (▲ Except DTS-63、644、648、65、66)

Soldering:  
 V = Lead Free Solderable  
 Q = Halogen Free

□ = Dome Phosphor bronze  
 (\*S = Dome Stainless steel)  
 (\*12x12 K、S、Y Unavailable)

Color of stem for operating force:  
 ▲ K = Black , 100gf  
 N = Brown , 160gf  
 R = Red , 260gf  
 S = Salmon , 320gf  
 ▲ Y = Yellow , 520gf  
 (▲ 12x12 K、Y Unavailable)

Dimension H :

◎ 6 X 6 mm  
 1 = 4.3 mm  
 2 = 5.0 mm  
 3 = 7.0 mm  
 44 = 7.3 mm(SQ.)x2.4 mm  
 48 = 7.3 mm(SQ.)x2.8 mm  
 5 = 9.51 mm  
 6 = 13 mm

◎ 12 x 12 mm  
 1 = 4.3 mm  
 4 = 7.3 mm (SQ.) x 3.8 mm  
 5 = 8.5 mm

Prod. Size :

6 = 6x6 mm  
 2 = 12x12 mm

□ = None Post  
 ▲ = With Post  
 < ▲ For 12x12 only >  
 Tactile Switch

## **SPECIFICATION**

### **△MECHANICAL**

Operation Force:520±130gf Yellow(Y)  
320±80gf Salmon(S)  
260±50gf Red(R)  
160±50gf Brown(N)  
100±50gf Black(K)

Stop Strength: Max 3kgf vertical static load continuously  
for 15 seconds

Stroke : (12x12) 0.35±0.1mm  
(6x6) 0.25+0.2/-0.1mm

Operation Temperature Range : -25°C to +70°C

Storage Temperature Range : -30°C to +80°C

### **△ELECTRICAL (6X6)**

Electrical Life : 300,000 cycles for 320gf,520gf  
500,000 cycles for 260gf  
1,000,000 cycles for 100gf,160gf

Rating : 50mA , 12 VDC

Contact Resistance : 100mΩ max

Insulation Resistance : 100MΩ min , 500 VDC

Dielectric Strength : 250 VAC / minute

Contact Arrangement : 1 pole 1 throw

## **MATERIAL**

△COVER : Stainless steel

△CONTACT DISC : Phosphor bronze with silver cladding  
(Standard)  
Stainless Steel(V-Option)

△TERMINAL : Brass with silver plated

△BASE : UL94V-0 Nylon High-Temp. Thermoplastic

△STEM : UL94V-0 Nylon High-Temp. Thermoplastic

Color : Black(100gf) , Brown(160gf) , Red(260gf)  
Salmon(320gf) , Yellow(520gf)

(Phosphor bronze)

### **△ELECTRICAL (12X12)**

Electrical Life: 100,000 cycles for 320gf

100,000 cycles for 260gf

200,000 cycles for 160gf

(Stainless Steel)

Electrical Life: 500,000 cycles for 260gf

1,000,000 cycles for 160gf

## **SOLDERING PROCESS**

△WAVE SOLDERING: Recommended solder temperature at 500°F(260°C)max. 5 seconds subject to PBC 1.6mm  
thickness ( For through hole type )

△Hand soldering : Use a soldering iron of 30 watts , controlled at 350°C approximately max 5 seconds while  
applying solder.

DTS-61.62 TUBE

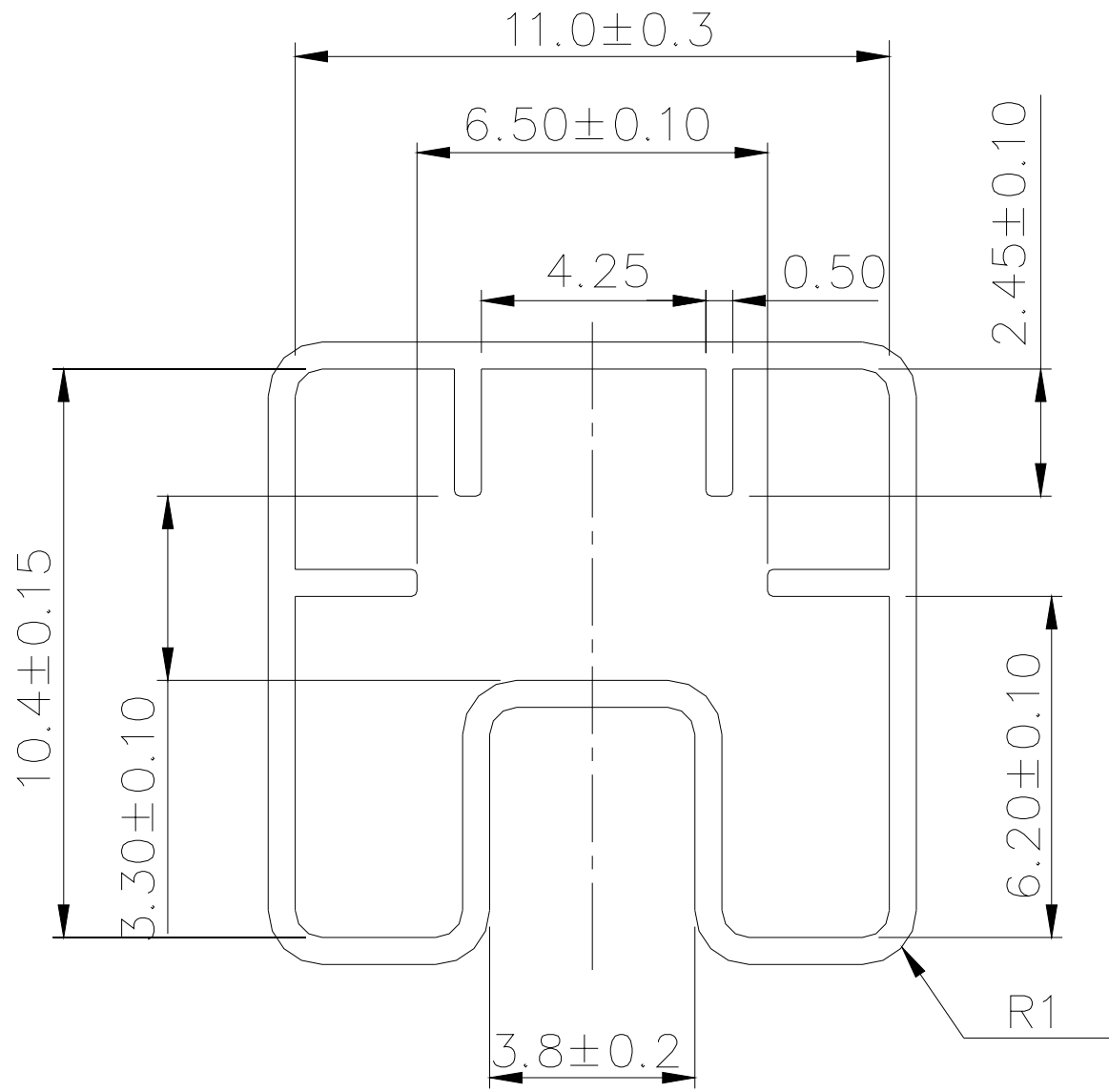

General Tolerance :  $\pm 0.2\text{mm}$

DTS-2 □ □ TUBE

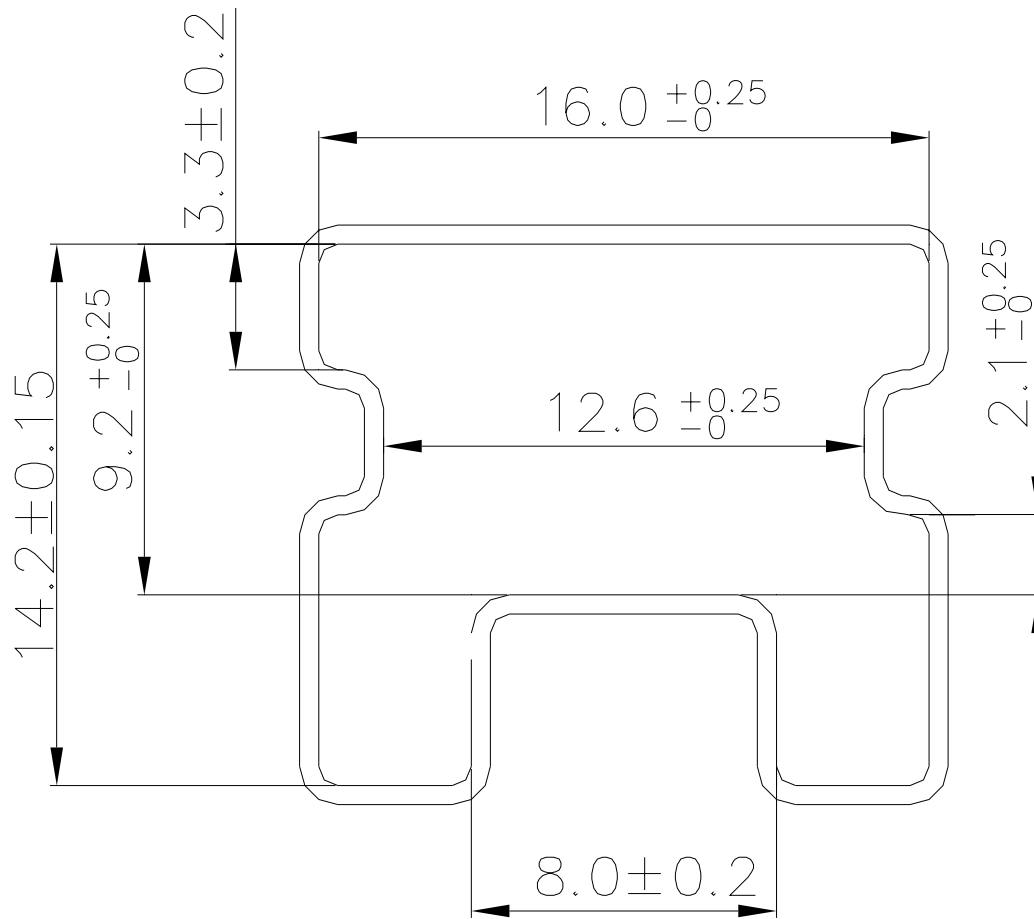

General Tolerance :  $\pm 0.2\text{mm}$