

L7113VGC/H

GREEN

Features

- ULTRABRIGHTNESS.
- WATER CLEAR LENS ARE AVAILABLE.
- OUTSTANDING MATERIAL EFFICIENCY.
- RELIABLE AND RUGGED.
- IC COMPATIBLE/LOW CURRENT CAPABILITY.

Description

The Green source color devices are made with InGaN on SiC Light Emitting Diode.

Package Dimensions

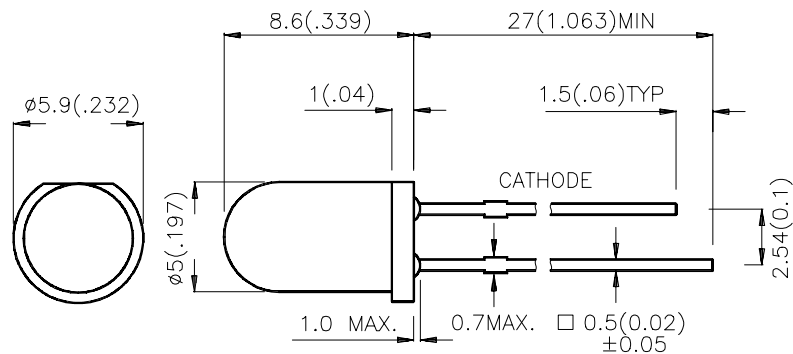

Notes:

1. All dimensions are in millimeters (inches).
2. Tolerance is $\pm 0.25 (0.01)$ " unless otherwise noted.
3. Lead spacing is measured where the lead emerge package.
4. Specifications are subject to change without notice.

Selection Guide

Part No.	Dice	Lens Type	Iv (mcd) @ 20 mA		Viewing Angle
			Min.	Typ.	2θ1/2
L7113VGC/H	GREEN (InGaN)	WATER CLEAR	8000	18000	20°

Note:

1. θ1/2 is the angle from optical centerline where the luminous intensity is 1/2 the optical centerline value.

Electrical Maximum Ratings at T_A=25°C

Symbol	Parameter	Device	Typ.	Max.	Units	Test Conditions
λ _{peak}	Peak Wavelength	Green	520		nm	I _F =20mA
λ _D	Dominate Wavelength	Green	525		nm	I _F =20mA
Δλ1/2	Spectral Line Half-width	Green	35		nm	I _F =20mA
C	Capacitance	Green	45		pF	V _F =0V;f=1MHz
V _F	Forward Voltage	Green	3.7	4.1	V	I _F =20mA
I _R	Reverse Current	Green		10	μA	V _R = 5V

Absolute Maximum Ratings at T_A=25°C

Parameter	Green	Units
Power dissipation	120	mW
DC Forward Current	30	mA
Peak Forward Current [1]	150	mA
Reverse Voltage	5	V
Operating/Storage Temperature	-40°C To +85°C	
Lead Solder Temperature [2]	260°C For 5 Seconds	

Notes:

- 1/10 Duty Cycle, 0.1ms Pulse Width.
- 4mm below package base.

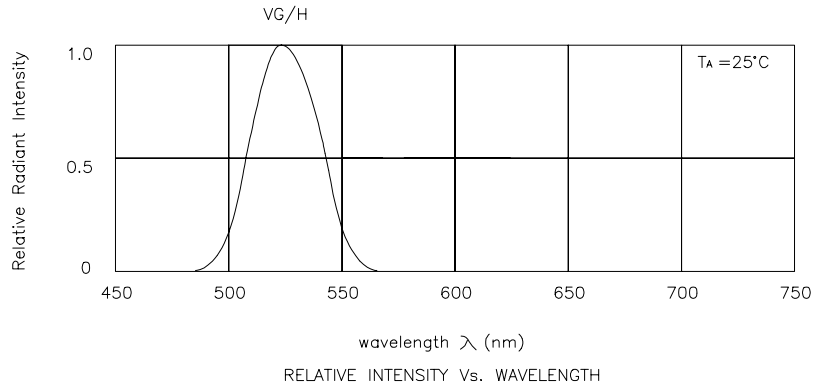

Green L7113VGC/H

