

L7104PBC/H BLUE

Features

- LOW POWER CONSUMPTION.
- SOLID STATE BLUE LIGHT SOURCE.

Description

The source color devices are made with InGaN on SiC Light Emitting Diode

Package Dimensions

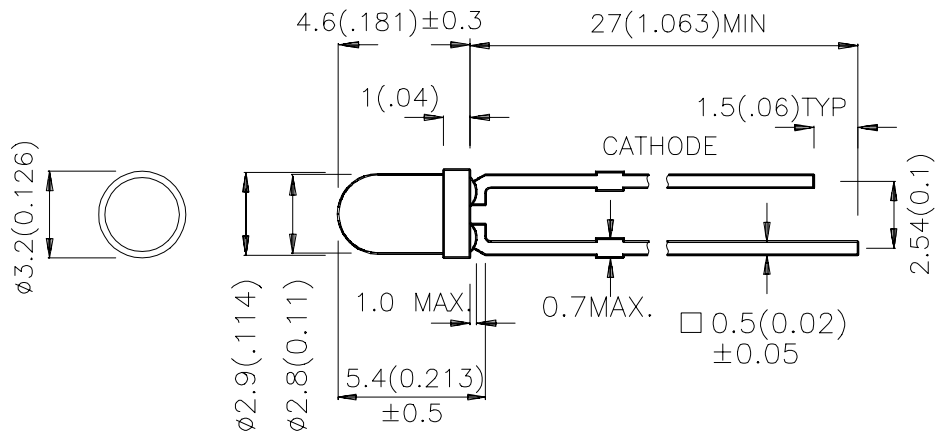

Notes:

1. All dimensions are in millimeters (inches).
2. Tolerance is $\pm 0.25 (0.01)$ unless otherwise noted.
3. Lead spacing is measured where the lead emerge package.
4. Specifications are subject to change without notice.

Selection Guide

Part No.	Dice	Lens Type	Iv (mcd) @ 20 mA		Viewing Angle
			Min.	Typ.	2θ1/2
L7104PBC/H	BLUE(InGaN)	WATER CLEAR	1200	2100	20°

Note:

1. θ1/2 is the angle from optical centerline where the luminous intensity is 1/2 the optical centerline value.

Electrical / Optical Characteristics at T_A=25°C

Symbol	Parameter	Device	Typ.	Max.	Units	Test Conditions
λ _{peak}	Peak Wavelength	Blue	467		nm	I _F =20mA
λ _D	Dominate Wavelength	Blue	470		nm	I _F =20mA
Δλ _{1/2}	Spectral Line Half-width	Blue	30		nm	I _F =20mA
C	Capacitance	Blue	110		pF	V _F = 0V, f=1MHz
V _F	Forward Voltage	Blue	3.7	4.3	V	I _F =20mA
I _R	Reverse Current	Blue		10	uA	V _R = 5V

Absolute Maximum Ratings at T_A=25°C

Parameter	Blue	Units
Power dissipation	108	mW
DC Forward Current	30	mA
Peak Forward Current [1]	100	mA
Reverse Voltage	5	V
Operating/Storage Temperature	-40°C To +85°C	
Lead Solder Temperature [2]	260°C For 5 Seconds	

Notes:

1. 1/10 Duty Cycle, 0.1ms Pulse Width.
2. 4mm below package base.

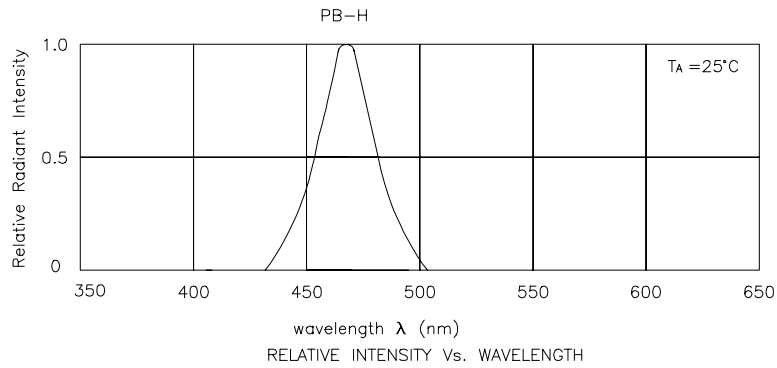

Blue L7104PBC/H

