

N3100A-9214	N Plug Crimp Right Angle	52Ω
-------------	---------------------------------	------------

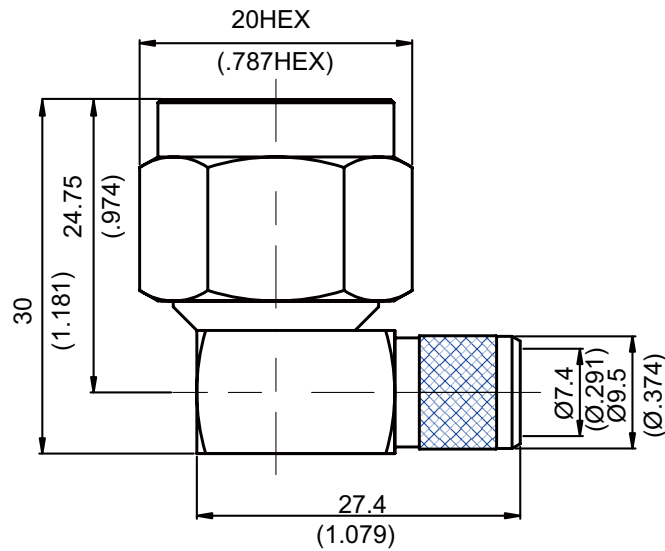





Parts	Material	Plating (Micro-inch)
Center Pin	Brass	Gold 5 Over Nickel 50 Over Copper 50
Barrel	Brass	Tin-Zinc-Copper-Alloy 100 Over Copper 50
Ferrule	Brass	Tin-Zinc-Copper-Alloy 100 Over Copper 50
Nut	Brass	Tin-Zinc-Copper-Alloy 100 Over Copper 50
Renbrock Ring	Brass	Tin-Zinc-Copper-Alloy 100 Over Copper 50
Gasket	Silicon	
Insulator	Teflon	
Contact Body	Brass	Silver 150 Over Copper 50
Body	Brass	Tin-Zinc-Copper-Alloy 100 Over Copper 50
Coupling Nut	Brass	Tin-Zinc-Copper-Alloy 100 Over Copper 50

Weight:
Suitable Cables: RG58, JBY195

This part number complies with RoHS.

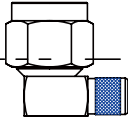
Notice: JYEBAO reserves the right to make modifications deemed appropriate.

CABLE ASSEMBLY INSTRUCTION

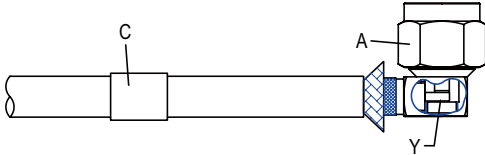
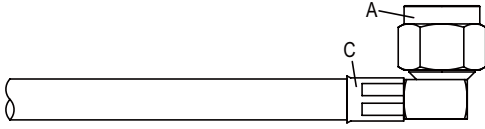
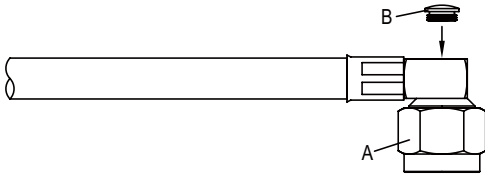
N3100A-9214	JYE BAO CO., LTD.			
N3100A-9214	DATE	2014/04/29	REV	—
A	B	C		
				
BODY	NUT	FERRULE		
DIAGRAM	ASSEMBLY INSTRUCTION			
	Step 1: STRIP AS SHOWN.			
	Step 2: SLIDE FERRULE " C " OVER CABLE. Step 3: WRAP THE BRAIDING UPWARDS. Step 4: SLIDE CENTER CONDUCTOR ON THE CONTACT PIN OF CONNECTOR " A " AND SOLDER IN " Y ".			
	Step 5: SLIDE FERRULE " C " TOWARDS THE CONNECTOR " A " AND CRIMP. (USE 10.7mm/0.421inch HEX SECTION OF INSERT-C)			
	Step 6: SCREWNUT " B " ON THE CONNECTOR " A ".			

This part number complies with RoHS.

Notice: JYEBAO reserves the right to make modifications deemed appropriate.